

MAŠINA SA ROTIRAJUĆOM RUKOM

Rotary

AUTOMATSKA ROTIRAJUĆA RUKA ZA STREČOVANJE FOLIJOM
AUTOMATIC ROTATING ARM STRETCH WRAPPING MACHINES



GENERALNI DISTRIBUTER I ZASTUPNIK ROBOPAC-a ZA SRBIJU

PakSistemi 
moć pakovanja

SOMBORSKA 5, 21000 NOVI SAD

Tel: +381216614469

e: office@paksistemi.com

w: www.paksistemi.com



Robopac

Kompanija ROBOPAC je osnovan 1982. godine i danas predstavlja svetskog lidera na polju mašina za strečovanje i paletiziranje, sa preko 7000+ proizvedenih mašina godišnje.

Kompanija je razvila 6 različitih tipova mašina za strečovanje visokog kvaliteta: samohodajuće robot mašine, paletizere sa rotirajućom rukom, paletizere sa okretnom platformom, horizontalne strečerice i mašine sa termosakupljajućom folijom.

Širok asortiman mašina koje mogu da zadovolje gotovo svaki zahtev i potrebu za pakovanje, velika baza dostupnih dilera kao i servisera spremih da izađu u susret svakom korisničkom zahtevu čini kompaniju ROBOPAC pravim liderom na globalnom nivou na polju mašina za pakovanje i paletiziranje.

PakSistemi
moć pakovanja



Rotary

ROTARY je idealno rešenje da se obmotaju nestabilni proizvodi.

Za mnoge industrije je često potrebno da se stabilizuje proizvod na paleti uz pomoć rotacione ruke. Ova mašina ima odlične tehničke i konstrukcijske karakteristike, koje mogu rešiti ovaj problem i idealan je izbor za pouzdano i efikasno obavljanje proizvoda streč folijom.

Kontrolna tabla je glavni pokretač Robopac-a, ovde leži srce mašine i tehnologije Robopac-a, kao što je Multilevel kontrola. Zahvaljujući ekranu od 7 inča u boji, ovaj kontrolni panel omogućava da se jednostavno i brzo kreiraju programi. Isporučuje se sa više memorije do 12 različitih programa.

Rotary / Rotary W

AUTOMATSKA ROTIRAJUĆA RUKA ZA STREČOVANJE FOLIJOM
AUTOMATIC ROTATING ARM STRETCH WRAPPING MACHINES

TEHNIČKE KARAKTERISTIKE / TECHNICAL FEATURES

MAŠINE / MACHINE	ROTARY / ROTARY W
radna visina / usable mast height (mm)	2000 std./2400 opt./2750 opt.
brzina rotacione ruke / arm rotation speed (rpm)	7÷12
brzina nosača folije (gore-dole) podesivo preko kontrolnog panela / carriage up/down speed adjustable from control panel (m/min)	2.5÷9
produktivnost / productivity (pallet/h)	30
minimalne dimenzije palete / minimum pallet dimensions (LxW) (mm)	400x400
maksimalne dimenzije palete / maximum pallet dimensions (LxW) (mm)	1400x1400
tip nosača folije / spool carriage type	FR/PDS/PVS
svetlosni senzor hitnog branika / light Sensor Emergency Bumper	standardno
snaga / power supply (V)	230V±15% 1Ph+N 50/60 Hz
tačka zaustavljanja faze / phase stopping point	standardno
lagani početak pokretanja / soft start	standardno
fotočelija za detekciju visine / load height sensing by photocell	standardno
maksimalne dimenzije hilzne / max spool dimension (Ø mm x H mm x kg)	300x500x20
debljina folije / film thickness (µm)	17÷35

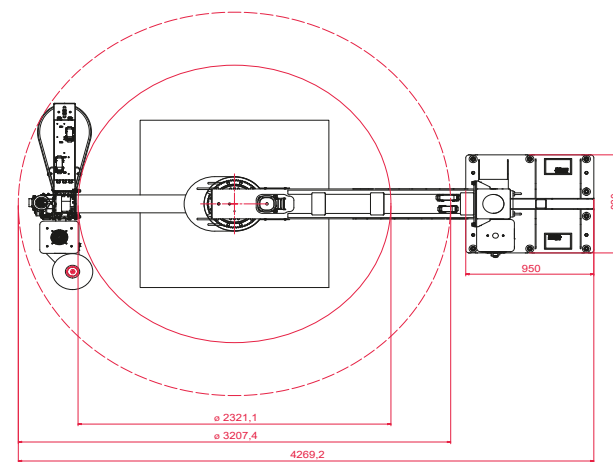
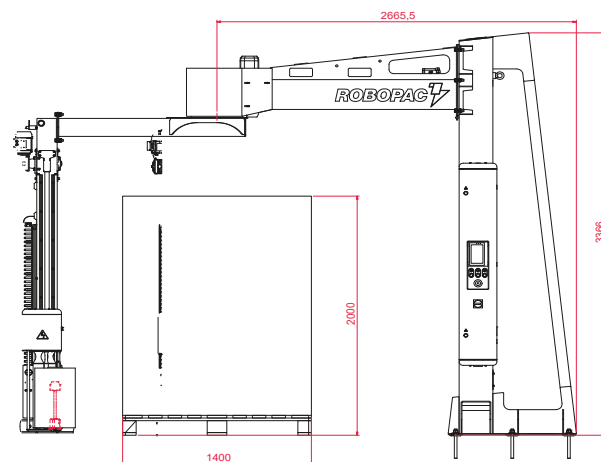

OPCIONO / OPTIONAL	ROTARY ROTARY W
radna visina / useful mast height 2000 mm	x
radna visina / useful mast height 2400 mm	o
radna visina / useful mast height 2750 mm	o
nosač FRD / carriage FRD	n.d.
nosač FR / carriage FR	x
nosač PGS / carriage PGS	n.d.
nosač PDS / carriage PDS	x
nosač PVS / carriage PVS	x
nosač rolne FR / carriage FR reel h750 mm	x
nosač rolne PGS / carriage PGS reel h750 mm	x
nosač rolne PDS / carriage PDS reel h750 mm	x
nosač rolne PVS / carriage PVS reel h750 mm	x
zatezanje folije / film tensioning	x
predistezanje folije / film pre-stretch	x
automatsko odsecanje folije / automatic film cut	o
varna letva / welder	n.d.
varna letva sa kontrastnom pločom / welder with contrast plate	n.d.
razdelnik / spreader	n.d.
podesivi uređaj za vezivanje i redukcije visine folije / variable roping device and reduction film height system	o
pritisna ploča / top plate	o
pokretanje sa udaljene lokacije / remote control start	o
Multilevel control	x
Rconnect	o

(X) standardno (O) opciono (n.d.) nije dostupno

Rotary / Rotary W

AUTOMATSKA ROTIRAJUĆA RUKA ZA STREČOVANJE FOLIJOM
AUTOMATIC ROTATING ARM STRETCH WRAPPING MACHINES



- ▶ KONTROLNI PANEI U BOJI OD 7" SA MULTILEVEL KONTROLOM
- ▶ ZIDNA KONFIGURACIJA
- ▶ ZA NESTABILNE I NESTANDARDNE PALETE
- ▶ IDEALNA ZA LOGISTIKU
- ▶ MOGUĆNOST OBAVIJANJA PALETA DO DIMENZIJA 1400x1400
- ▶ ROTIRAJUĆA RUKA PODESIVA PREMA DIMENZIJAMA PALETE

- ▶ COLOUR TOUCH SCREEN 7" WITH MULTILEVEL CONTROL
- ▶ WALL CONFIGURATION
- ▶ UNSTABLE A/O IRREGULAR PALLETS
- ▶ IDEAL FOR LOGISTICS
- ▶ POSSIBILITY TO WRAP PALLET TILL 1400x1400 mm
- ▶ ROTATING ARM ADJUSTABLE DEPENDING BY THE PALLET



SA MLC TEHNOLOGIJOM
"MULTI-LEVEL CONTROL"
WITH MLC TECHNOLOGY
"MULTI-LEVEL CONTROL"



PakSistemi 
moć pakovanja

ROBOPAC 

Savršenstvo tehnologije

MLC MULTILEVEL CONTROL

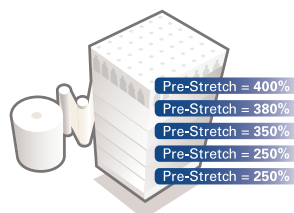

Multi-level varijabilno
PREDISTEZANJE

Multi-level variable
PRE-STRETCH

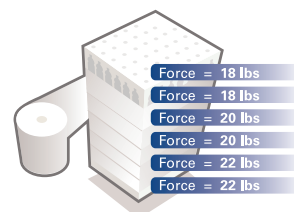

Multi-level varijabilno
**PODESIVA SILA
ZATEZANJA**

Multi-level variable
**CONTAINMENT
FORCE**

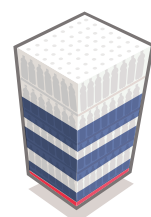

Strateško
**POSTAVLJANJE
folije**

Strategic film
PLACEMENT

NISKI TROŠKOVI UPRAVLJANJA

MLC tehnologija omogućava najbolju stabilizaciju proizvoda sa minimalnim korišćenjem folije. Zahvaljujući sili zatezanja, MLC isporučuje najbolju količinu folije.

- ▶ SMANJENJE TROŠKOVA FOLIJE OD 35% DO 55%
- ▶ NAJBOLJA STABILIZACIJA TERETA
- ▶ SMANJENJE OŠTEĆENJA PROIZVODA DO 40%

THE LOWEST TOTAL COST OF OWNERSHIP

MLC is the technology that allows the best load stabilization with the minimum quantity of film. MLC deliver the right amount of film at the exactly the right containment force.

- ▶ REDUCES FILM COST BY 35% TO 55%
- ▶ IMPROVES LOAD CONTAINMENT
- ▶ REDUCES PRODUCT DAMAGE BY 40%



INOVACIJA I KONEKCIJA U SLUŽBI KUPCA
INNOVATION AND CONNECTION AT THE CUSTOMER SERVICE

RConnect, tehnološko napredni sistem, koji kombinuje inovacije i konekciju, omogućavajući kontrolu rada mašine i potpunu podršku krajnjem kupcu.

Rconnect, a technologically advanced monitoring system that combines innovation and connection, allowing complete control of the operation of the machines and a total support to the final customer.



PREDNOSTI BENEFITS

- ▶ MAKSIMALNA PRODUKTIVNOST
MAX PRODUCTION
- ▶ OPTIMIZACIJA I MONITORING PERFORMANSA
PERFORMANCE OPTIMIZATION & MONITORING
- ▶ PREVENTIVNO ODRŽAVANJE
PREDICTIVE MAINTENANCE
- ▶ BRZO REŠAVANJE PROBLEMA
DOWNTIME REDUCTION
- ▶ PLUG & PLAY
- ▶ INDUSTRIA 4.0
INDUSTRY 4.0



GENERALNI DISTRIBUTER I ZASTUPNIK ROBOPAC-a ZA SRBIJU

Tel: +381216614469 e: office@paksistemi.com w: www.paksistemi.com