

Tehničke informacije

Diptank 60



Karakteristike

- Vreme trajanja ciklusa: 3-5 sekunde
- Maksimalni kapacitet: 60 kg
- Digitalna kontrola temperature
- Dubina potapanja: 220 mm • Hidrauličke operacije
- Optimalna higijena
- Kućište od prohroma
- Izolacione loptice sa isparavanje



Specifikacije	Diptank 60
Dimenzije komore DxŠxV (mm)	500x600x220
Dimenzije mašine DxŠxV (mm)	770x790x1320
Napon	400V-3-50Hz 230V-3-50Hz 220V-3-60Hz
Trajanje ciklusa 50 Hz/60 Hz (sec.)	3 - 5
Snaga (kW)	9,0
Težina (kg)	120

Dimenzije (mm)

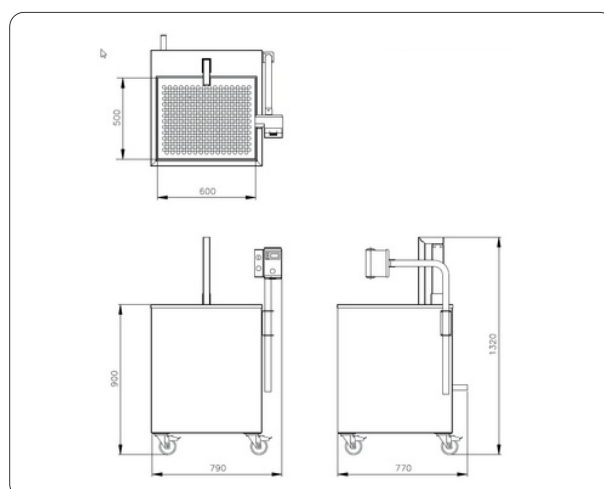

Pak Sistemi doo
Generalni uvoznik i
serviser Henkelmana
Bajči Žilinskog 5a,
21000 Novi Sad, Srbija
Tel: +381 (0) 21 661 4469

Email:
office@paksistemi.com

Email servisne podrške:
service@paksistemi.com